



Installation Instructions

Console Megashifter

1982-1992 Camaro and Firebird*

Part Number 80692

© 2000, 2001 by B&M Racing and Performance Products LLC

This **B&M Megashifter** is designed to fit in the consoles of 1982-1992 Chevrolet Camaros and Pontiac Firebirds*. In 1982 these vehicles were equipped with three speed automatic transmissions. Since 1983 they have been equipped with four speed automatic transmissions. Shifter #80692 is for three speed automatic and four speed automatic transmissions. The shifters are equipped with neutral start and backup light switches and a five foot shift cable. If the shifter is used with the four speed automatic transmission (TH-700R4), the blocker pin and E-clips shown in **Figures #2 and #3** must be removed.

Please read the instructions and review the illustrations thoroughly before beginning the installation.

The mechanical components of this shifter are precision made and assembled at our factory. Any modification or disassembly of these parts can cause the shifter to malfunction and will void the warranty. You should disassemble only those items outlined in the instructions.

The vehicle should be about 2 feet off the ground for ease of installation. Use jack stands, wheel ramps or a vehicle lift. Make sure the vehicle is firmly supported before attempting to work on it.

INSTALLATION

STEP 1. Remove the knob from the stock shifter. Pull firmly up on the detent button and it will pop out. Remove the snap ring inside of the knob and pull off the knob.

STEP 2. Remove the top cover of the console. On the Camaro remove six screws (some of the screw heads on the cover plate may be dummy screws) and on the Firebird remove four exterior screws and one in the ashtray. Remove the console light from the cover.

STEP 3. Disconnect the two cables from the shifter. The left hand cable is the shift cable and the right hand cable is the Park lock

cable. Remove the wiring plug from the shifter body. Unbolt and remove the shifter mechanism (**See Figure #1**). Remove the cable bracket and the selector lever from the transmission (**See Figure #4**). Remove the shift cable from the vehicle.

STEP 4. The Park lock cable must be wired in the Park position (fully in) so that the steering column lock will work and will allow the key to be removed. The cable should also be secured inside of the console out of the way. After wiring the cable in this position check to see that the steering column lock works correctly, and that you can remove the key. **WARNING: With the interlock disabled in this manner it is possible to lock the steering column at any time, so be careful not to turn the key to the "LOCK" position while the car is moving.**

STEP 5. Assemble the neutral safety and reverse light switches to the bracket using two #4-40 x 1" screws and nuts, as shown in **Figure #2**. Beware, over tightening the switch attachment screws will crack the switch housings. Install the switch assembly on the shifter. To adjust the switches, loosen the screws and slide the switches in or out as required, then retighten the screws.

STEP 6. Install the cable on the shifter as shown in **Figure #2**. The cable attachment tab should be bolted to the outside surface of the shifter base using 1/4" x 1/2" hex bolt, lock washer and nut. Install the E-clip that secures the cable to the cable pin.

STEP 7. Install the **B&M** rear mounting bracket to the floor (**See Figure #1**). Bolt the front mounting bracket to the front of the shifter. Put the shifter on the rear bracket and put the bolts in finger tight. Using the slots in the front mounting bracket as a guide, mark the positions on the floor pan for the front mounting bolts. Remove the shifter and drill two 9/32" holes for the front mounting screws. Replace the shifter guiding the cable through the hole and rubber seal in the floor.

Bolt the shifter in place.

STEP 8. Just before the final installation of the shifter in the vehicle, attach the indicator cable to the side of the shifter as shown in **Figure #3**. (The other end of the indicator cable is attached to the **B&M** cover plate.) The indicator cable bracket is secured to the shifter mechanism with two #6 x 3/8" sheet metal screws and the eyelet on the end of the indicator cable is secured to the cable pin by a supplied small E-clip. If the shifter is being used with the four speed automatic transmission, the blocker pin and E-clips shown in **Figures #2 and #3** must be removed.

STEP 9. Route the shifter cable as shown in **Figure #4**. Avoid sharp bends that will kink and damage the cable.

STEP 10. Install the **B&M** selector lever in position on the transmission using the stock selector lever nut (**See Figure #5**). Torque the nut to 23 ft. lbs. The lever should move smoothly front to back with a positive click in each gear position.

STEP 11. Remove the two transmission oil pan bolts from the middle of the left side of the oil pan. Install the cable bracket in position (**See Figure #5**). The bracket must be installed with spacers between the pan and the bracket. Install the two 5/16x1.00" bolts (or M8x25 mm for metric transmissions) supplied and tighten 12-13 ft. lbs. Do not overtighten as this can damage the pan gasket.

STEP 12. Route the shifter cable according to **Figure #4**. Avoid kinks and sharp bends and route the cable away from hot engine or exhaust parts. Remove the two rubber boots, one large nut, and a large lockwasher from the threaded end of the shifter cable. Slide the end of the cable into the cable bracket. Install the large nut and the lockwasher loosely over the end of the cable. Install two rubber boots onto the end of the cable. Install the swivel on the threaded end of the cable and position it in the center of the threaded portion.

STEP 13. Move the transmission selector lever by hand to full rear position (Low).

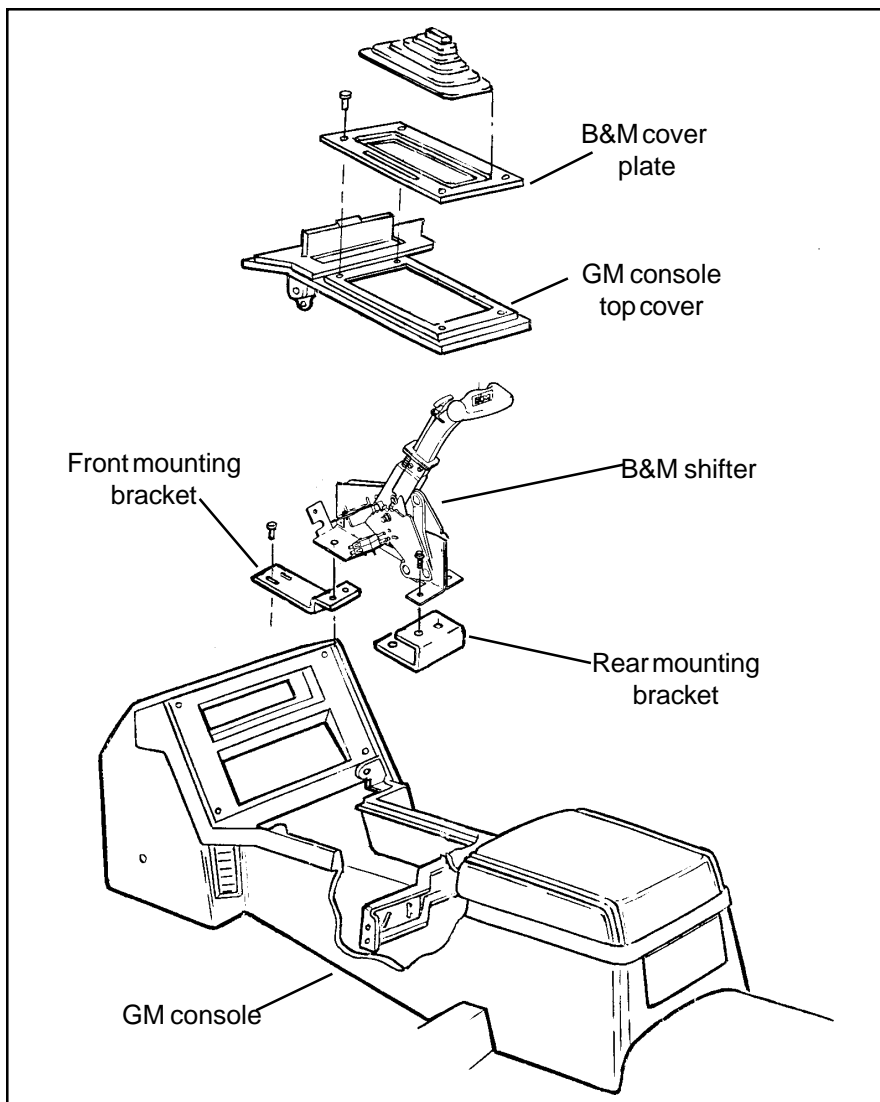

Figure #1

Operate the shifter lever to the Low gear position (ratcheted all the way back). Adjust the large nuts on the cable so that the swivel will slide into the **front** hole on the selector lever. Tighten the large nuts completely. Be sure that the swivel will slide freely in and out of the hole in the selector lever. **Note: The shifter will not operate correctly unless the front hole in the shift lever is used.**

Leave the swivel out of the hole and move the selector lever to Park, all the way forward. Also move the shifter to the Park position (all the way forward). Reinsert the swivel into the **front** hole in the selector lever. Check to see that the swivel will slide freely in and out of the **front** hole in the selector lever in this position. If it does not slip in freely, adjust the swivel slightly until it will slip into the hole in the lever.

Move the shifter back to the Low gear position and check that the swivel will still slide easily in and out of the **front** hole in the selector lever. Operate the shifter through all the gear positions. Check to make sure the swivel will slide in and out of the **front** selector lever hole in each gear position. The

shift cable is now correctly adjusted. Install the cotter key supplied with the shifter into the swivel and spread the key ends.

If you have a problem, **DO NOT FORCE THE SHIFTER**, this will damage the cable, the shifter or the transmission. Simply start at the beginning and carefully check all your steps.

STEP 14. Disconnect the battery ground cable before beginning to wire the neutral start and reverse light switches. Locate and identify the neutral start and reverse light wires on the stock wiring plug removed in **Step 4**. Cut wires from plug then strip 1/4" insulation off the wires and lengthen them with 4-6" of additional wire. Put slip-on terminals on the end of the lengthened wire. Crimp the terminals onto the wires using a crimping tool or pliers. Connect the neutral start wires (the purple and yellow wires) to the **LOWER** switch and the reverse light wires (dark blue and light green) to the **UPPER** switch (See **Figure #2**). Tape the terminal connections to prevent shorts. Reconnect the battery ground cable, disconnect the coil wire and set the parking brake. Check the switch operation by

attempting to start the motor in each shifter position. **The starter must crank only when shifter is in the Park or Neutral position.** Check the reverse light operation. Adjust the switches if required. Reconnect the coil wire.

Note: Some models will have two additional wires, orange with black and black with white going to the plug. **Do not** join these wires. Tape the ends of these wires separately to prevent grounding. With the factory shifter, these are switched together in the Neutral and Park positions. This circuit locks out the converter clutch and changes the idle speed. This circuit can be restored by the addition of a relay (not supplied) operated by the neutral safety switch circuit (See **Figure #6**). The relay must be for 12 VOLTS DC operation and have a minimum rating of one amp. (Radio Shack #275-206 is satisfactory.)

STEP 15. Cut the bulb socket from the stock console light. These wires will be connected to the indicator light on the shifter. Remove the indicator assembly from the stock console cover plate. A small file or a hot knife works well.

STEP 16. Place the supplied template on top of the GM console top cover. On the Camaro, locate the holes marked "A" over the four stock holes around the shifter opening. On the Firebird, locate it with the two holes marked "B" over the stock screw holes. Tape the template onto the cover plate and transfer the cutout shape to the cover with a scribe or felt tip marking pen. Drill 1/4" holes in the corners of the rectangular area. Cut away a rectangular area with a key hole saw. File or sand the edges of the cut.

STEP 17. Install the GM console top cover, using the original hardware. Feed the **B&M** top plate through the hole in the cover.

STEP 18. Install the indicator light bulb in its socket on the shifter cover plate. Connect the wires that were cut in **Step 15**.

STEP 19. Snap the shift position window into the top plate. The window snaps in from the top with the tabs inserting into the slots at either end of the window opening. Place the shifter in the Park position then remove the T-Handle from the shifter. Place the cover plate over the stick and onto the top of the tower. Route the indicator cable around the front of the shifter so that it has a free radius and will not bind. Run the shifter through all of the gears to check the operation of the indicator. If the indicator needs adjustment, loosen the screws holding the indicator cable clamp to the cover plate and slide the cable bracket to adjust the indicator position. (Retighten these screws carefully since they are threaded into plastic.) Attach the cover plate to the tower with four Phillips head screws.

STEP 20. Slide the boot over the stick and install it into the cover plate. Note that the front of the boot had "FRONT" on the inside of the rubber. After the boot is installed in the cover plate and into the stick, install the T-Handle and the jam nut. Tighten the jam nut when the handle is properly oriented.

OPERATION

The **B&M Megashifter** normally functions as a straight gate detent shifter from Park to Reverse to Neutral to Drive and as a ratchet shifter from Neutral to all forward gears. Refer to the following instructions for proper operation:

STRAIGHT GATE MODE: With the trigger in the upper position, the shifter functions in the STRAIGHT GATE mode. The handle travels in a direct line forward and backward from Park to Drive. The trigger must be raised up to clear the stop gates while going through the gear positions.

RATCHET SHIFT MODE: The RATCHET SHIFT mode allows firm, positive no-miss upshifts and downshifts through all positions from 1 (Low gear) to Neutral. To switch from STRAIGHT GATE to RATCHET operation, first operate shifter to the Drive position. The trigger will snap down approximately 3/4". The shifter is now in the RATCHET mode, Drive gear position. The shifter will only operate in the RATCHET mode between Neutral and Low, it will not ratchet to Reverse or Park. This is done to prevent accidental shifting into Reverse.

SHIFTING IN THE RATCHET MODE: Move the shift handle forward or backward with a quick firm action until it hits the internal stops, and allow it to spring return to the center position. The shifter is now ready for the next shift.

To switch the shifter from RATCHET mode

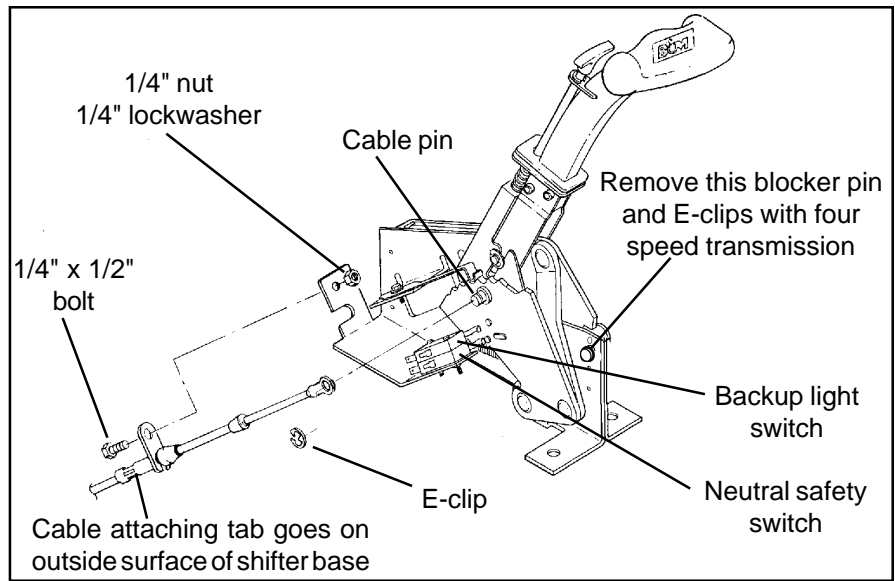

Figure #2

back to the STRAIGHT GATE mode, operate the shifter to the Drive gear position, pull up firmly on the trigger to engage the STRAIGHT GATE mode and move the handle forward to Neutral, Reverse and Park.

REMEMBER: To switch from the STRAIGHT GATE mode to the RATCHET mode or from RATCHET mode to STRAIGHT GATE mode you must be in the Drive gear position. Refer to the shift indicator gear position.

SPECIAL NOTE: If the instructions for oper-

ating your shifter seem complicated, **DO NOT BECOME ALARMED.** You will find that in actual use the shifter will be extremely easy to operate after a minimal amount of experience. Caution: The shifter is an important controlling mechanism of your vehicle and can create serious driving hazards when any part is loose, missing or misadjusted. After you have installed your shifter we recommend you review the instructions to assure a complete and proper installation.

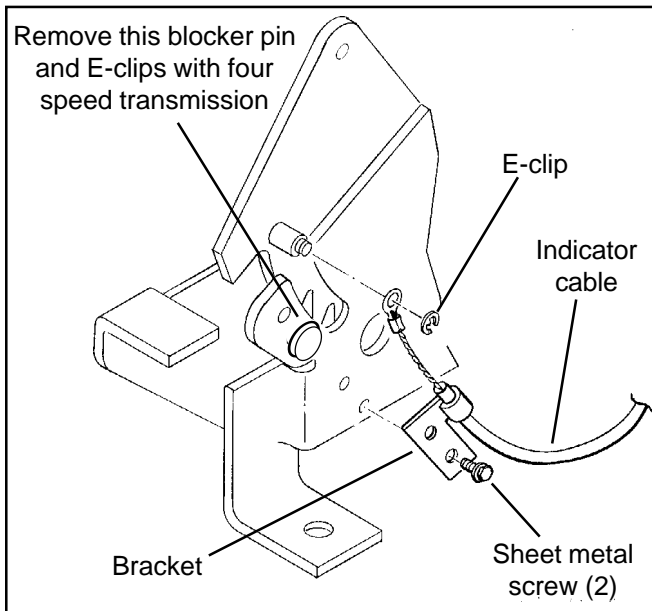

Figure #3

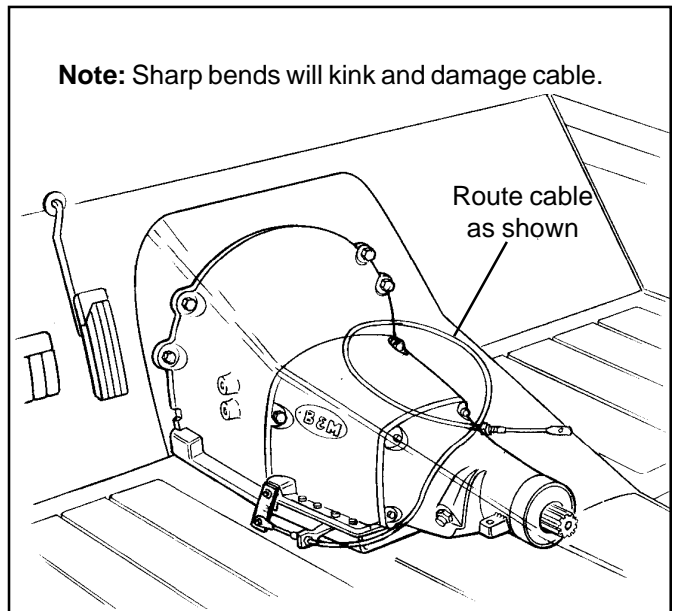

Figure #4

WARNING

PERIODIC INSPECTION AND MAINTENANCE OF YOUR SHIFTER IS RECOMMENDED TO ENSURE THAT THE MECHANISM IS WELL LUBRICATED, FREE FROM DIRT OR RUST AND THAT THE CABLE IS PROPERLY ADJUSTED. LACK OF MAINTENANCE COULD RESULT IN A FAILURE INCLUDING A FAILURE OF THE REVERSE LOCKOUT SAFETY FEATURE.

General Motors TH-200, TH-350, TH-400, TH-200-4R and TH-700-R4

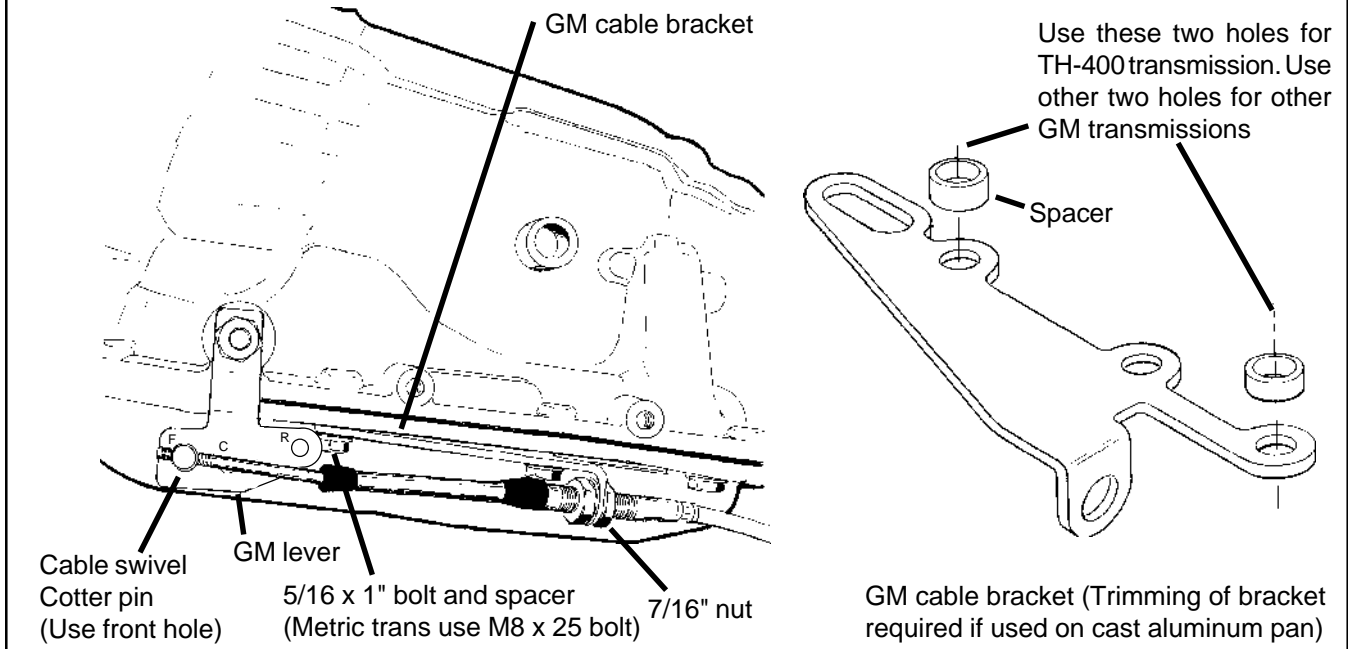

Figure #5

Check List

- ___ Ignition/steering column lock works correctly. Key can be removed and steering column locks when key is removed. **Step 4.**
- ___ Cable is securely fastened to shifter and end is held with E-clip. **Step 6.**
- ___ Cable is routed as shown in **Figure 4** and securely fastened to transmission and swivel is held with cotter key. **Step 12.**
- ___ Shifter is properly adjusted. **Step 13.**
- ___ The neutral start and reverse light switches are connected and properly adjusted to prevent engine from starting in forward gears and reverse. **Step 14.**
- ___ There is no debris in shifter mechanism.
- ___ Cover plate is securely fastened and shift position indicator is operating properly. **Step 20.**
- ___ Shifter moves freely in all positions as described in Shifter Operation.
- ___ If your shifter is not working properly do not attempt to drive your vehicle. Make sure you have followed all instructions. If the shifter is broken or defective return it to your **B&M** dealer.

IMPORTANT

Before installing the T-handle onto the shifter put a little grease on the threads of the stick. The aluminum of the T-handle may gall on the threads of the stick and make it impossible to remove the T-handle from the stick. If this occurs it can cause the stick to break if you use excessive force while attempting to remove the T-handle from the stick.

Tool List

- | | | | |
|---|-------------------------|-----|-----------------------------------|
| 1 | Common Screwdriver | 1 | 1/8", 9/32" and 1/4" Drill Bits |
| 1 | Phillips Screwdriver | 1 | Drill Motor |
| 1 | #15 Torx bit or driver | 2/4 | Jack Stands |
| 1 | 10mm Wrench | 1 | 0-50 lb.ft. Torque Wrench |
| 1 | 1/4" Wrench | 1 | File |
| 1 | 5/16" wrench | 1 | Wire Stripper |
| 2 | 7/16" Wrench | 1 | Wire Crimper |
| 1 | 9/16" Wrench | 1 | Pliers |
| 2 | 11/16" Wrench | 1 | Electrical Tape |
| 1 | 10mm Socket and ratchet | A/R | Nylon Tie Wraps (to secure cable) |

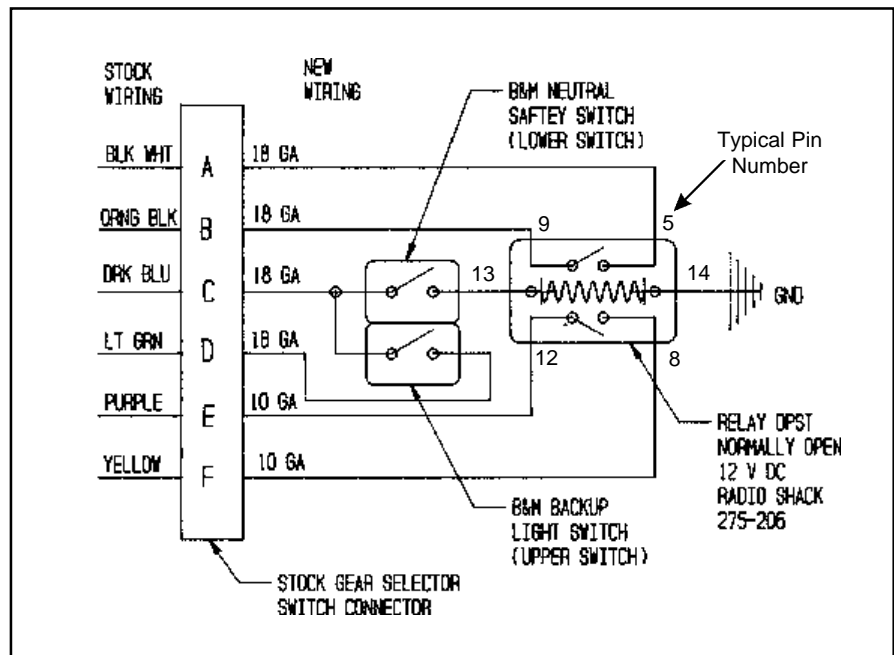

Figure #6